

**Entry-Level Price...  
...Cutting Edge Performance!**

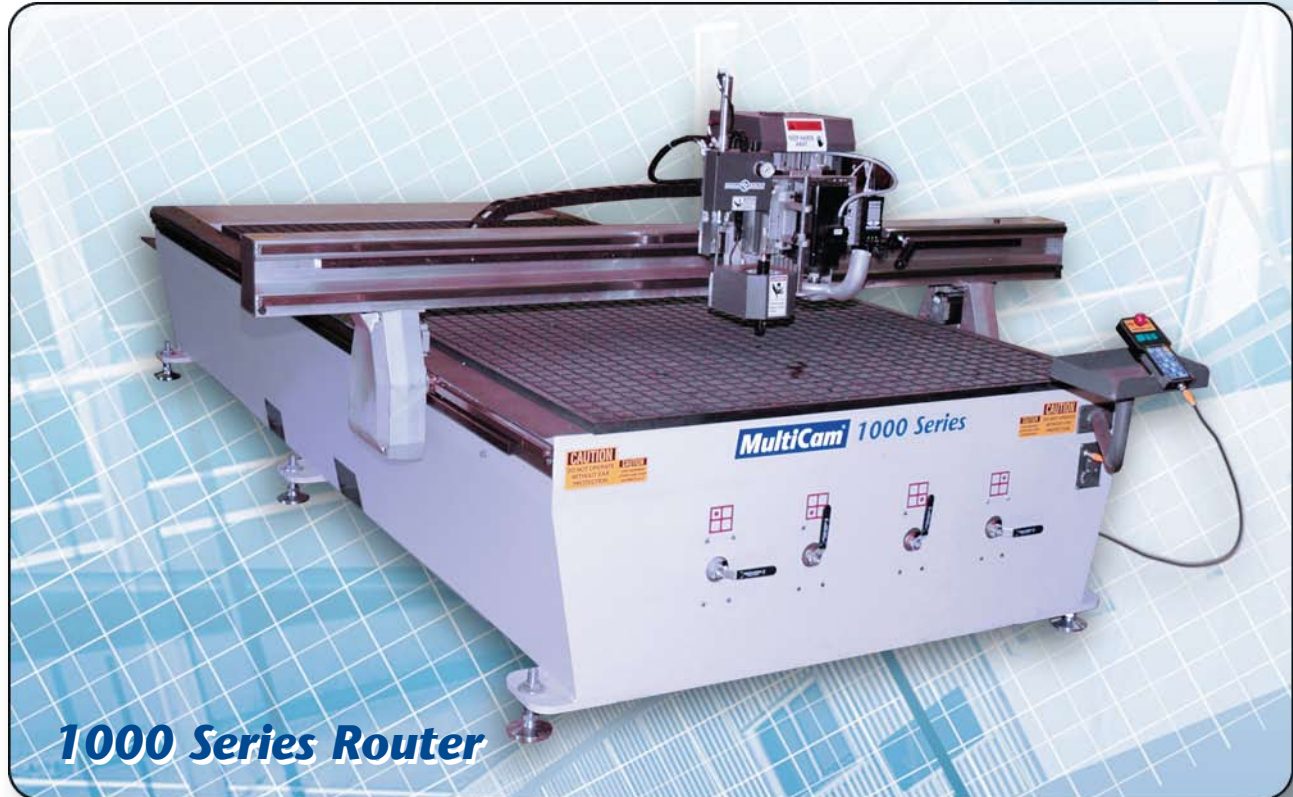

**1000 Series Router**

The industry challenge was to build a rigid, reliable CNC Machine platform with excellent performance at an entry-level price. Over 15 years of cutting-edge, industry-leading design experience resulted in MultiCam's 1000 Series Router, a machine that offers a price/performance breakthrough in CNC Router design.

The MultiCam 1000 Series Router has more standard features than any other machine in its class, and is the perfect solution for sign manufacturing and applications requiring value, performance and price in a CNC Router.

**MultiCam<sup>®</sup>**  
**CNC Cutting Solutions**

1025 West Royal Ln. DFW Airport, TX 75261 • PO Box 612048 Dallas, TX 75261 • 972.929.4070  
fax 972.929.4071 • email [sales@multicam.com](mailto:sales@multicam.com) • [www.multicam.com](http://www.multicam.com)

## 1000 Series Specifications

No machine offers more standard features than the MultiCam.

- Solid steel frame construction
- High-frequency 4hp spindle
- EZ Control user-friendly operator interface
- Automatic Tool Calibration
- High Speed 3-axis Motion Controller
- Precision dual X-axis micro stepping drives
- Cast dust collector shroud/pressure foot
- 25 mm linear ball bearing rails for maximum stiffness



### EZ Control

MultiCam EZ Control is one of the most powerful yet easy-to-use motion control systems available on machine tools today. No wonder MultiCam named its motion system EZ Control!

- Electronic depth safety system
- Z-axis management
- Tool compensation
- Cut speed override
- Spindle RPM override
- 8 MB of memory with unlimited file-size transfer capabilities
- Standard Ethernet TCP/IP or RS232 direct connections



### Working Surfaces

For a low cost manual clamping working surface, choose from aluminum t-slot table vacuum plenum construction or choose the medium pressure phenolic grid tops with and without vacuum zoning. Choose from a selection of MultiCam vacuum pump options.



## 1000 Series Specifications

### Base Frame Design

A solid steel frame design is standard on the popular 1000 Series CNC Router. The new 1000 Series Router frame provides a heavy and accurate linear platform which translates into vibration free motion for clean smooth cuts. Fork lift tubes are integral to facilitate rigging and installation. Precision datums are machined into the X-axis beams to allow accurate linear bearing positioning.



### Gantry

The Gantry tube is engineered for maximum stiffness from aircraft quality aluminum extrusion. Rigidity is ensured by 10mm wall thickness and internal I-beam structure. References for the precision linear bearings are extruded in the design and have excellent parallelism. The rack is tucked up in the front of the extrusion in a position to minimize swarf and chip contamination.

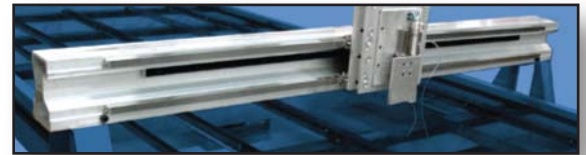

### Gantry Supports

Gantry supports are cast aluminum. They are machined on a four-axis horizontal machining center to guarantee perpendicularity. The castings give very stiff support to the gantry tube.



### Linear Bearings

Standard 25 mm linear ball bearing profile rails with stainless steel spring strip covers

- High rigidity and top load capacities in all load directions
- Lowest possible noise level and best running characteristics
- High torque load capacity
- 4 bearing packs per axis
- 30,400 Nm or 22,421 lb-ft dynamic capacity per pack



## 1000 Series Specifications

### Lead Screw Assembly

The 1000 series utilizes a ½" diameter stainless steel lead screw. This is held firmly in place by a precision mounting block with dual angular contact ball bearings for high axial force loads. A brass lead screw nut carries the Z-axis load.

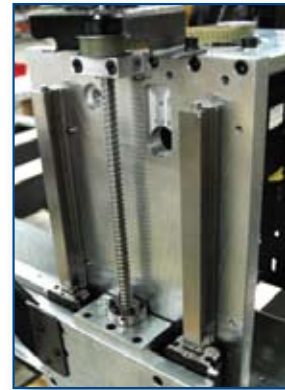

### Drive Motor System

The 2 phase digital, brushless, synchronous electric motors Multicam has selected for the 1000 Series have undergone extensive testing. The inductance and resistance of the windings are optimized for system smoothness. The integrated digital motor drives have also been optimized to run these motors efficiently.



### Drive Assembly

The transmissions on both the X-axis and Y-axis are both based on an aluminum casting and feature steel cable urethane belt drives. The output pinions are supported by a dual bearing arbor with wide bearing separation for optimum stiffness.



### ATC (Automatic Tool Changer)

The 1000 series machine is available with an optional Linear Automatic Tool changing system. The frame of the table has been extended so that the tool changer does not cut into or reduce the standard working area. The number of tool locations is dependent on the width of the machine. All ATC systems come standard with Automatic Tool Calibration and the tool change routines are built into the controls which simplifies integration to your favorite CAM software.



# 1000 Series Specifications

## Standard Accessories



Leveling Feet



Tool Box



Operation Manual

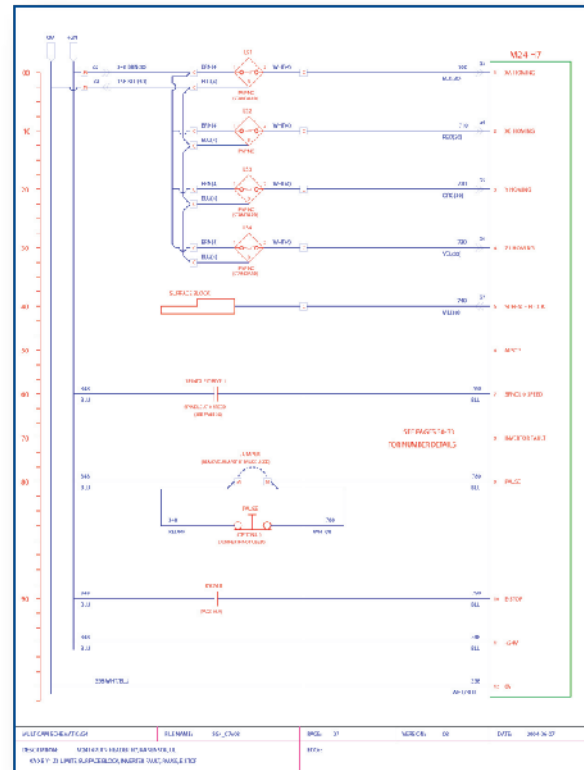

Electrical Schematics

# 1000 Series Specifications

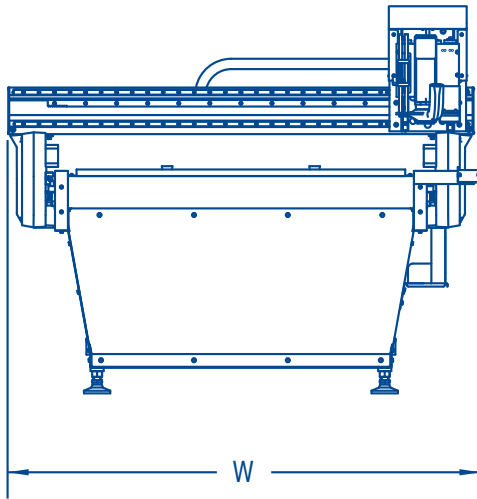
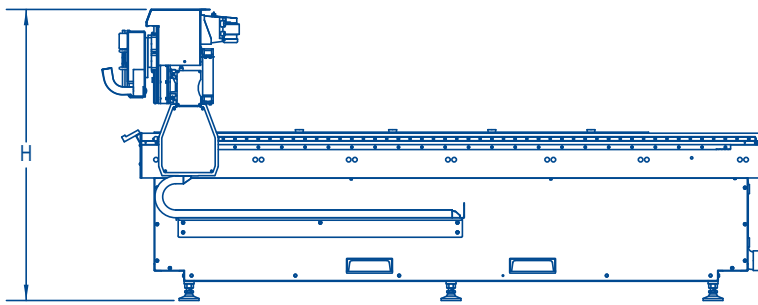
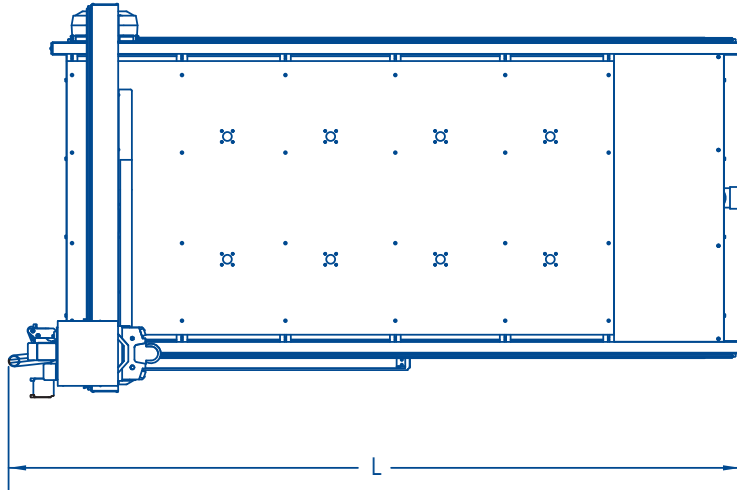

## 1000 Series Specs (inches)

- Z-Axis Clearance: 4.5
- Z-Axis Travel: 6"
- Repeatability: +/- .001"
- Cutting Speed: 450 ipm
- Rapid Traverse: 600 ipm
- Drive System X and Y axis: Rack and Pinion
- Drive System Z axis: Lead Screw
- Standard Work Surface: Aluminum T-Plate Extrusion

## Size Chart (inches)

MODEL	L	W	H	WORKING AREA	WEIGHT LBS.
1-103	155	71	54	50 x 100	2612
1-204	177	81	54	60 x 120	3157
1-205	199	81	54	60 x 144	3474
1-304	177	101	54	84 x 120	3828
1-305	199	101	54	84 x 144	4193
1-306	225	101	54	84 x 170	4988

## 1000 Series Specs (metric)

- Z-Axis Clearance: 114.3
- Z-Axis Travel: 152.3
- Repeatability: +/- .0254
- Cutting Speed: 450 ipm
- Rapid Traverse: 600 ipm
- Drive System X and Y axis: Rack and Pinion
- Drive System Z axis: Lead Screw
- Standard Work Surface: Aluminum T-Plate Extrusion

## Size Chart (metric)

MODEL	L	W	H	WORKING AREA	WEIGHT Kg
1-103	3937	1803	1371	1270 x 2540	1184
1-204	4495	2057	1371	1524 x 3048	1431
1-205	5054	2057	1371	1524 x 3657	1575
1-304	4495	2565	1371	2133 x 3048	1736
1-305	5054	2565	1371	2133 x 3657	1901
1-306	5715	2565	1371	2133 x 4318	2262

**MultiCam**

**1000 Series**